

Delta Mixer - Model PGF Flange Mount

Delta's *super duty* cast iron mixer for the most difficult mixing applications, superior to aluminum mixers, especially in aggressive environments.

Features

- ◆ Permanently greased bearings
- ◆ Aluminum/Cast Iron Housing
- ◆ Variety of propellers available
- ◆ TEFC enclosure is standard
- ◆ Other enclosures are available upon request
- ◆ Variable speed drives are also

| Model No. | HP | Voltage ph. | rpm | Shaft Length L | Shaft Dia. S | G in. | A in | D in Single | D in. Dual | W in. | E in. | M in. |
|-----------|-----|-------------|-----|----------------|--------------|-------|------|-------------|------------|-------|-------|-------|
| PGF-0 | 1/3 | 110/1/60 | 300 | 48" | 3/4" | 11.7 | 9.3 | 12 | 11 | 1.5 | 9 | 5.5 |
| PGF-1 | 1/2 | 110/1/60 | 300 | 48" | 3/4" | 11.7 | 9.3 | 12 | 11 | 1.5 | 9 | 5.5 |
| PGF-2 | 1/2 | 460/3/60 | 300 | 48" | 3/4" | 11.7 | 9.3 | 12 | 11 | 1.5 | 9 | 5.5 |
| PGF-3 | 3/4 | 110/1/60 | 300 | 48" | 3/4" | 11.7 | 9.3 | 13 | 12 | 1.5 | 9 | 6.5 |
| PGF-4 | 3/4 | 460/3/60 | 300 | 48" | 3/4" | 11.7 | 9.3 | 13 | 12 | 1.5 | 9 | 6.5 |
| PGF-5 | 1 | 110/1/60 | 300 | 60" | 1" | 15.5 | 9.3 | 14 | 13 | 1.5 | 10 | 6.5 |
| PGF-6 | 1 | 460/3/60 | 300 | 60" | 1" | 15.5 | 9.3 | 14 | 13 | 1.5 | 10 | 6.5 |
| PGF-7 | 1.5 | 460/3/60 | 300 | 60" | 1 1/4" | 16 | 12 | 15 | 14 | 1.5 | 10 | 7.5 |
| PGF-8 | 2 | 460/3/60 | 300 | 60" | 1 1/4" | 16 | 12 | 16 | 15 | 1.5 | 10 | 7.5 |

Overall Dimensions

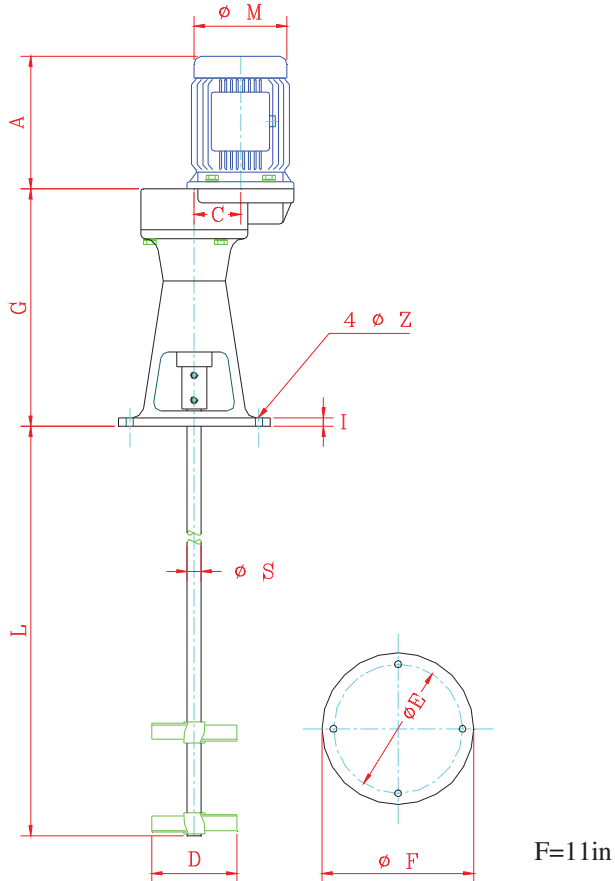

Typical Mixer Installation

