

Delta Mixer - Gear Drive Model PG

Delta's heavy duty mixer for the most difficult mixing applications.

Features

- ◆ Permanently greased bearings
- ◆ Aluminum/Cast Iron Housing
- ◆ Variety of propellers available
- ◆ TEFC enclosure is standard
- ◆ Other enclosures are available upon request
- ◆ Variable speed drives are also available

Model No.	HP	Voltage ph.	rpm	Shaft Length L	Shaft Dia. S	G in.	A in.	D in Single	D in. Dual	W in.	E in.	M in.
PG-0	1/3	110/1/60	350	48"	3/4"	11.7	9.3	10	8	1.5	2	5.5
PG-1	1/2	110/1/60	350	48"	3/4"	11.7	9.3	12	10	1.5	2	5.5
PG-2	1/2	460/3/60	350	48"	3/4"	11.7	9.3	12	10	1.5	2	5.5
PG-3	3/4	110/1/60	350	48"	3/4"	11.7	9.3	13	11	1.5	2	6.5
PG-4	3/4	460/3/60	350	48"	3/4"	11.7	9.3	13	11	1.5	2	6.5
PG-5	1	110/1/60	350	60"	1"	15.5	9.3	14	12	1.5	2	6.5
PG-6	1	460/3/60	350	60"	1"	15.5	9.3	14	12	1.5	2	6.5
PG-7	1.5	460/3/60	350	60"	1 1/4"	16	12	15	13	1.5	2 1/4	7.5
PG-8	2	460/3/60	350	60"	1 1/4"	16	12	16	14	1.5	2 1/4	7.5

Overall Dimensions

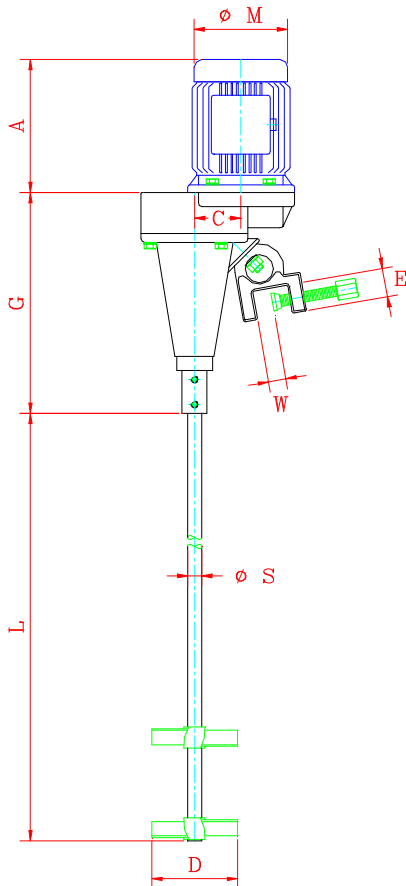

Typical Mixer Installation

