

# Model 3N1-direct or gear drive

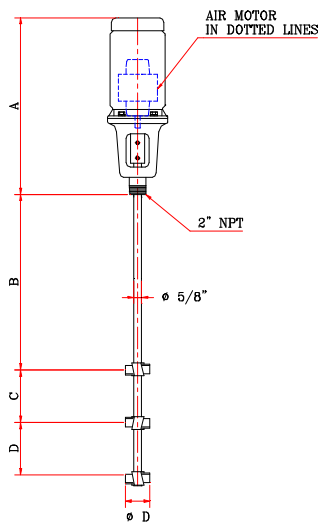

Model No.	HP	Voltage ph.	rpm	Shaft Length L	Shaft Dia. S	Dia in Single	Dia in. Dual	A in	B in.	C in.	D in.
3N1-0	1/3	110/1/60	1750	32"	5/8"	3	3	13.5	18	6	6
3N1-1	1/2	110/1/60	1750	32"	5/8"	4	3	13.5	18	6	6
3N1-3	3/4	110/1/60	1750	32"	3/4"	5	4	13.5	10	10	10
3N1-0A	1/3	AIR DRIVE	1750	32"	5/8"	4	3	13.5	18	6	6
3N1-1A	1/2	AIR DRIVE	1750	32"	5/8"	5	4	13.5	14	8	8
3N1-2A	3/4	AIR DRIVE	1750	32"	3/4"	5	4	13.5	14	8	8
3N1-3A	1	AIR DRIVE	1750	32"	3/4"	6	5	13.5	10	10	10

Standard 3N1 Mixer is supplied with one propeller

## Selection Table

Common Fluids	Gasoline Water	Blood	SAE10 Oil Olive Oil	Paint Glucose	Catsup Caster Oil	Glycerol Molasses
Viscosity CPS	1	100	250	500	1000	2500
<b>Tank Size</b>						
55 gal.drums	3N1-0	3N1-0	3N1-1	3N1-1	*PG-1	*PG-2
100 gal.tank	3N1-1	3N1-1	3N1-3	3N1-3	*PG-2	*PG-3
250 gal.tank	3N1-1	3N1-3	3N1-3	*PG-2	*PG-3	*PG-5

