

# Delta Mixers Spare Parts List

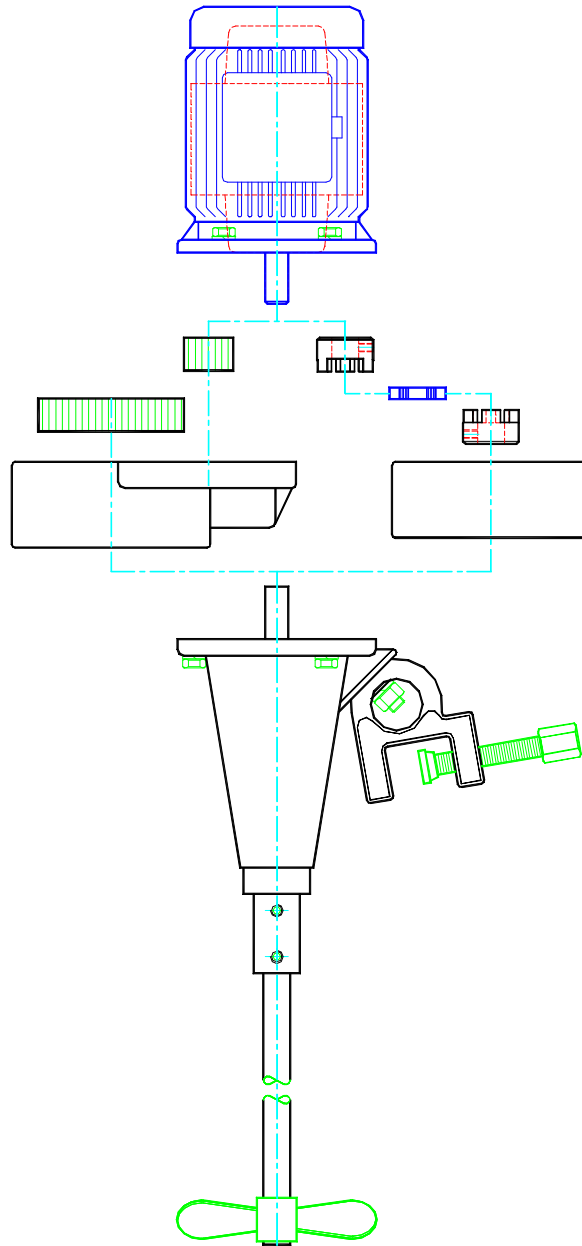

Ph. 905.827.93123    Fx. 905.827.9318  
E-mail [more@deltamixers.com](mailto:more@deltamixers.com)

## Model 3N1 Spare Parts List .30—.50 HP

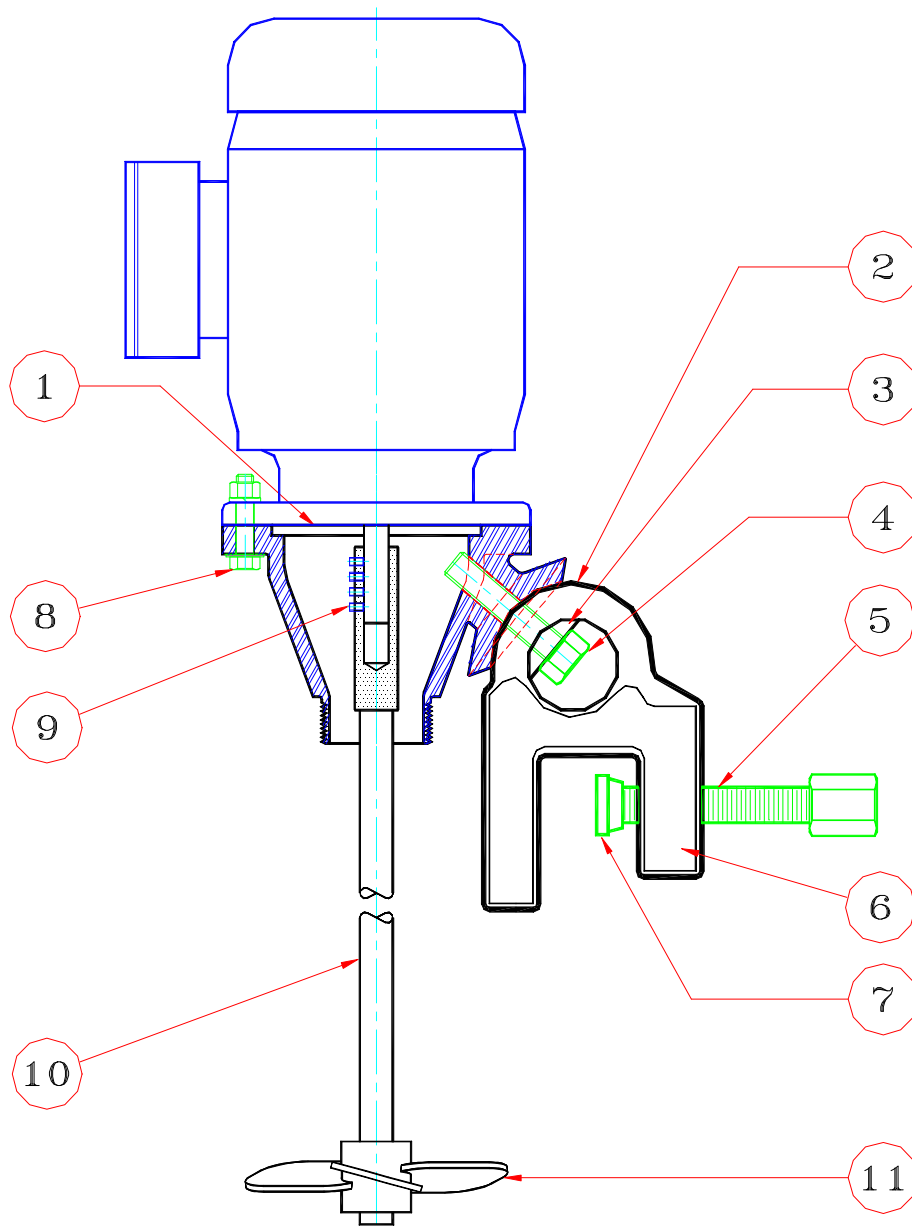

### Item Number

- 1- Body
- 2- Clamp Washer
- 3- Clamp Screw Washer
- 4- Clamp Screw
- 5- Clamp Spindle
- 6- Clamp
- 7- Clamp Screw Collar
- 8- Body Screw
- 9- Coupling & Set Screw
- 10- Shaft
- 11- Propeller

## Model 3N1 Spare Parts List .75 HP

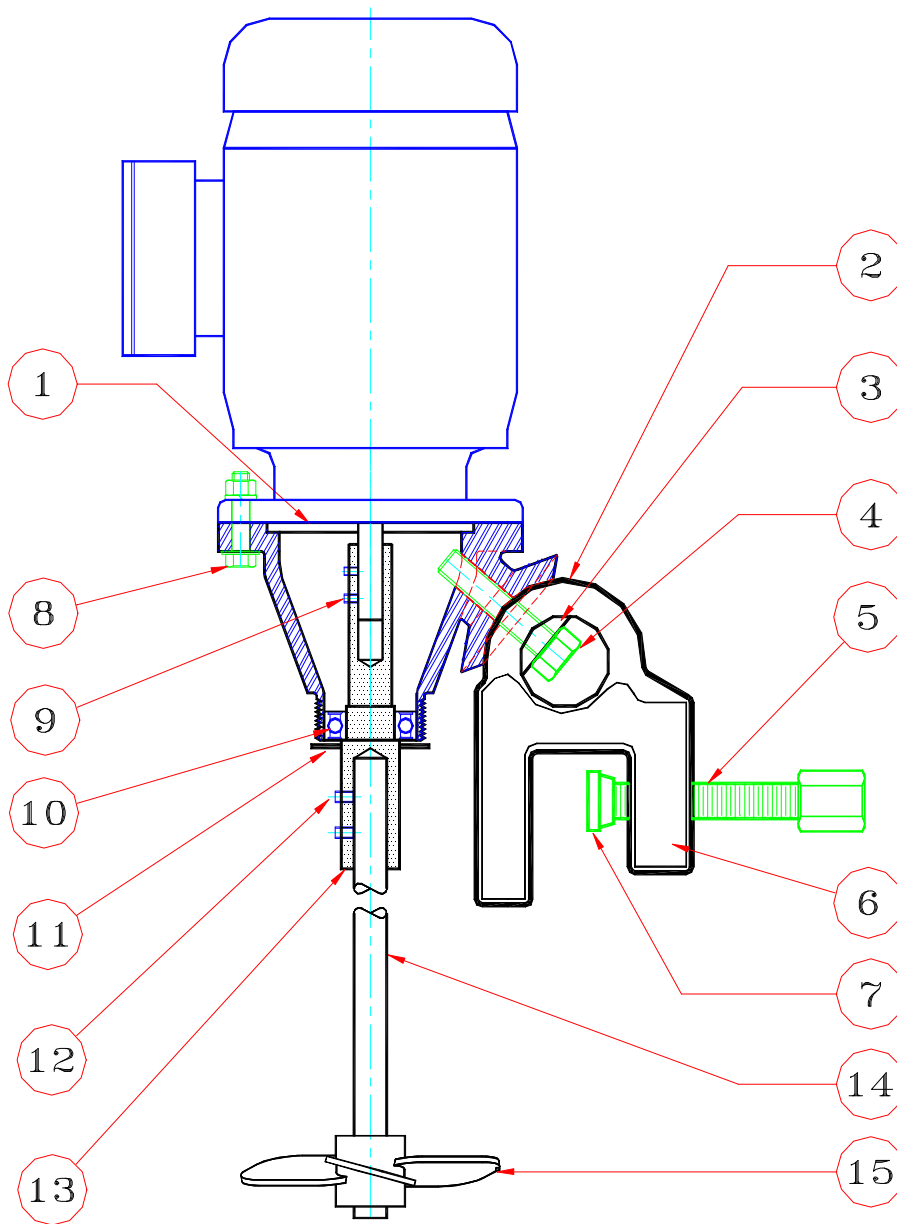

### Item Number

- 1- Body
- 2- Clamp Washer
- 3- Clamp Screw Washer
- 4- Clamp Screw
- 5- Clamp Spindle
- 6- Clamp
- 7- Spindle Collar
- 8- Body Screw
- 9- Coupling Set Screw
- 10- Bearing
- 11- EPDM Flinger
- 12- Set Screws
- 13- Stub Shaft
- 14- Shaft
- 15- Propeller

## Model PD Spare Parts List .30—.75 HP

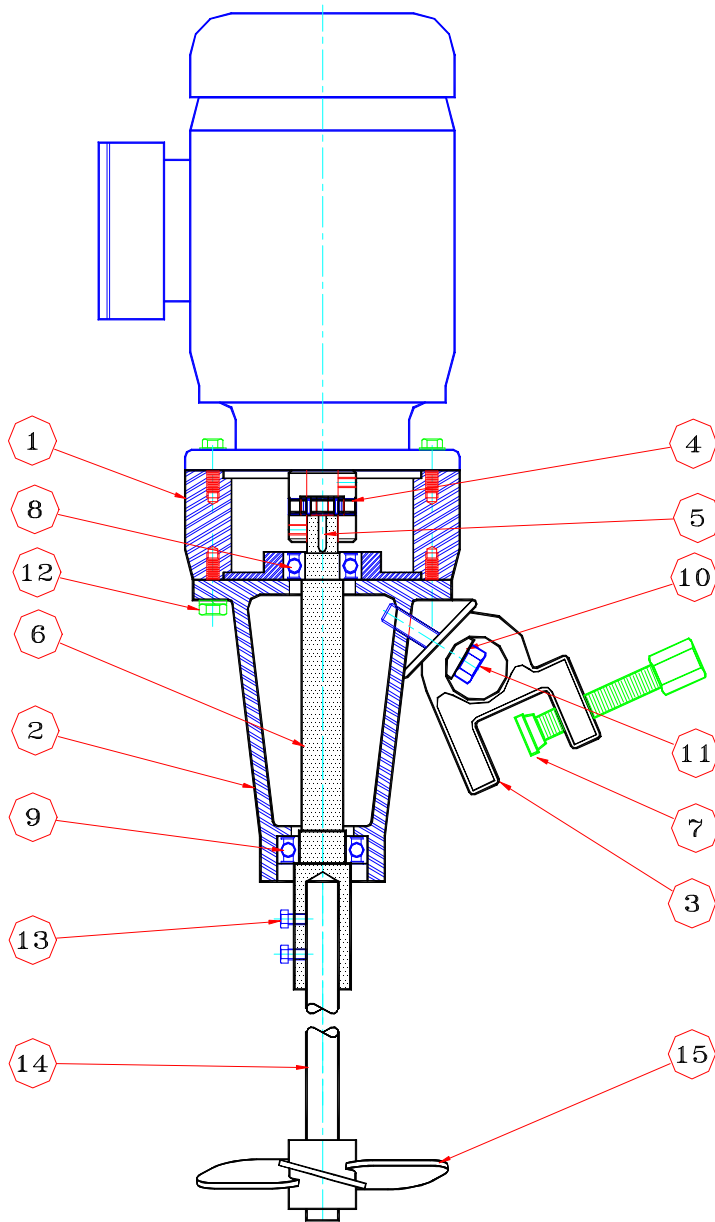

### Item Number

- 1- Motor Adaptor-D
- 2- Bearing Hosing
- 3- Clamp
- 4- Coupling
- 5- Shaft Key
- 6- Spindle
- 7- Clamp Screw Collar
- 8- Top Bearing
- 9- Bottom Bearing
- 10- Clamp Washer
- 11- Clamp Screw
- 12- Adapter Screw
- 13- Spindle Screws
- 14- Shaft
- 15- Propeller

## Model PG Spare Parts List .30—.75 HP

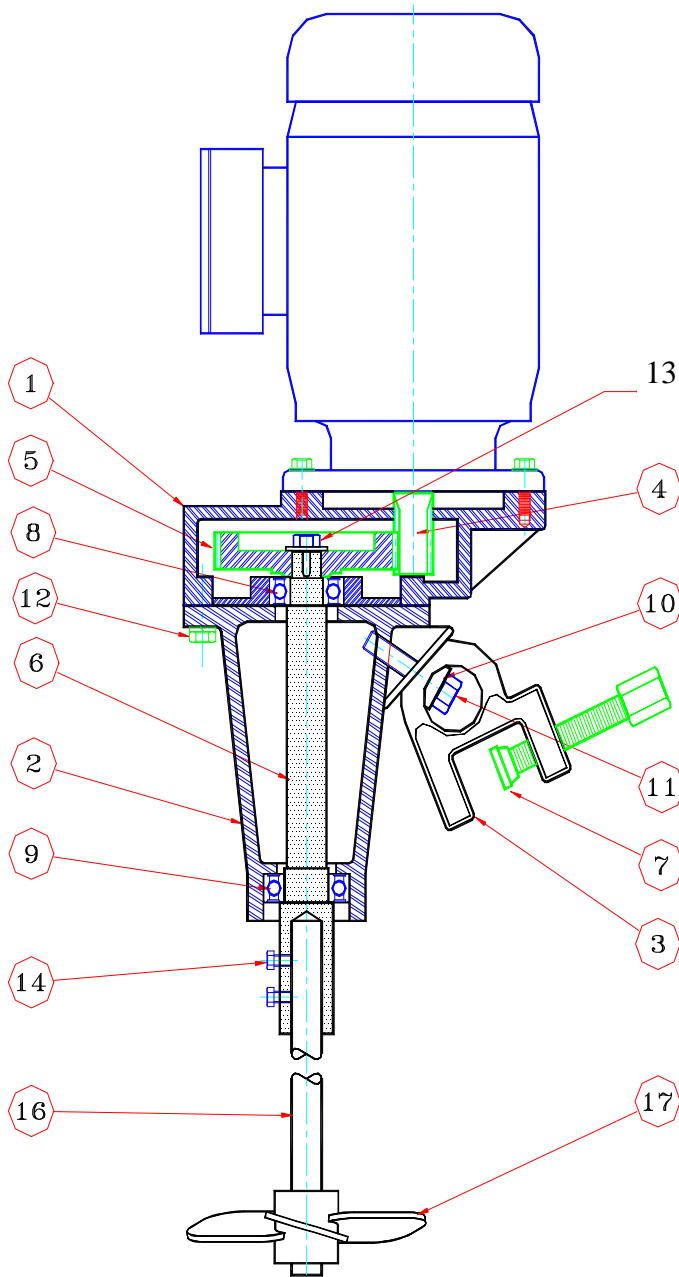

### Item Number

- 1- Motor Adaptor-G
- 2- Bearing Hosing
- 3- Clamp
- 4- Small Gear
- 5- Large Gear
- 6- Spindle
- 7- Clamp Screw Collar
- 8- Top Bearing
- 9- Bottom Bearing
- 10- Clamp Washer
- 11- Clamp Screw
- 12- Hosing Screw
- 13- Gear Screw & Washer
- 14- Spindle Screws
- 16- Shaft
- 17- Propeller

## Model PDF Spare Parts List .30—.75 HP

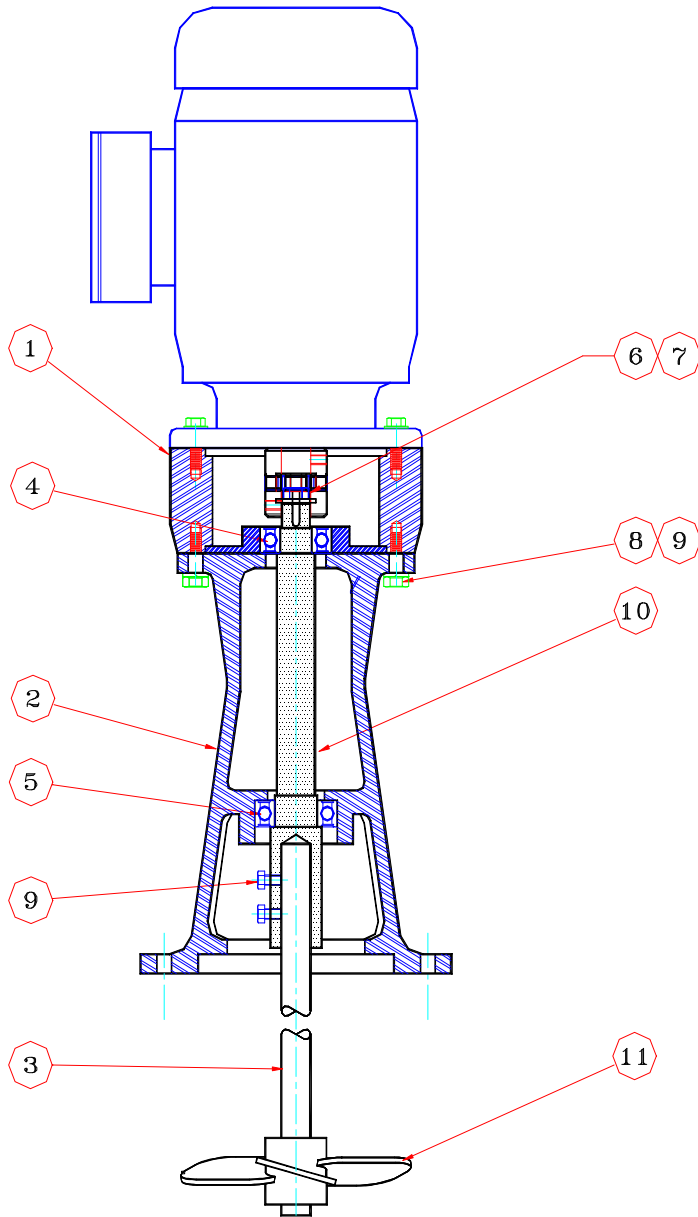

### Item Number

- 1- Motor Adaptor-D
- 2- Bearing Housing
- 3- Shaft
- 4- Top Bearing
- 5- Bottom Bearing
- 6- 7 Coupling Assy.
- 7- Screw Washer
- 8-9 Frame Screw & Washer
- 9- Spindle Screw
- 10- Spindle
- 11- Propeller

## Model PGF Spare Parts List .30—.75 HP

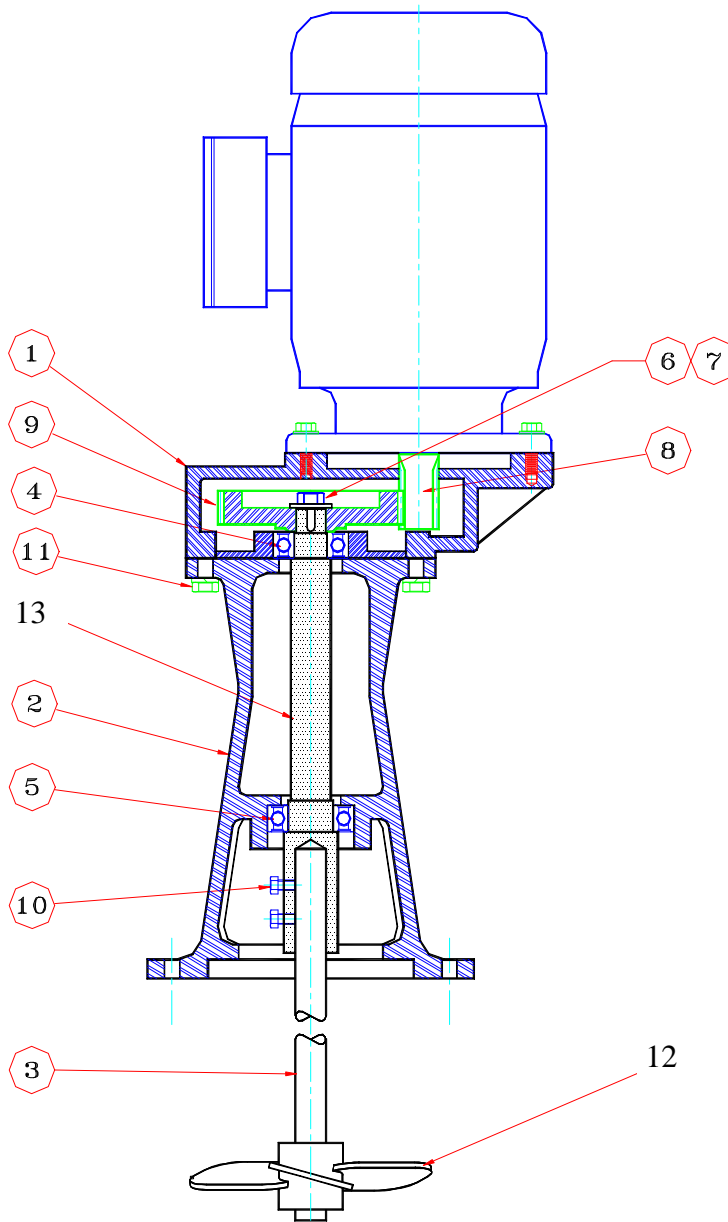

### Item Number

- 1- Motor Adaptor-G
- 2- Bearing Housing
- 3- Shaft
- 4- Top Bearing
- 5- Bottom Bearing
- 6.7- Screw & Washer
- 8- Small Gear
- 9- Large Gear
- 10- Spindle Screw
- 11- Frame Screw
- 12- Propeller
- 13- Spindle

## Proper Mixer Positioning

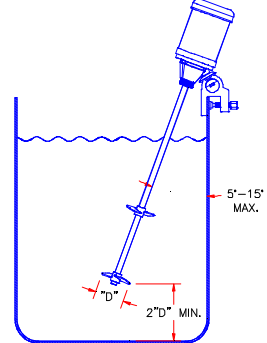
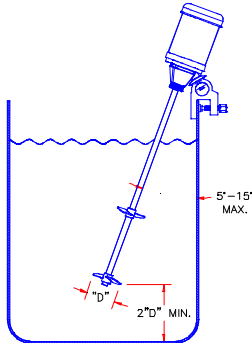
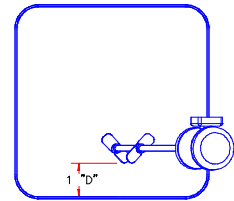
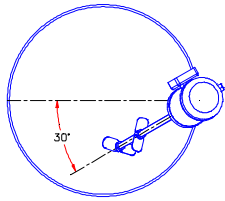

"T" = TANK DIAMETER

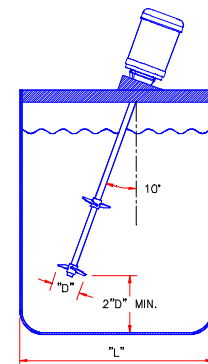
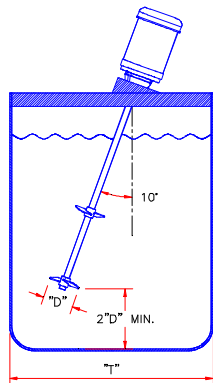
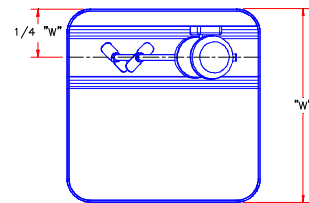
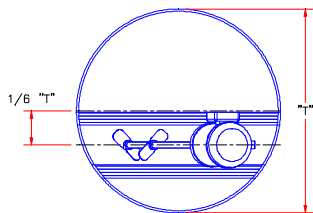

"D" = IMPELLER DIAMETER



**DELTA  
EQUIPMENT**

A DIVISION OF PBH INDUSTRIES LTD.

2400-4 Wyecroft Rd. Oakville, ON L6L 6M8

Ph. 905.827.9312

Fax. 905.827.9318

website [www.deltamixers.com](http://www.deltamixers.com)

e-mail [more@deltamixers.com](mailto:more@deltamixers.com)